

Temposonics®

Magnetostrictive Linear Position Sensors

ET SSI Data Sheet

- High operating temperature
- Compact sensor housing
- ATEX / IECEx / CEC / NEC certified



MEASURING TECHNOLOGY

The absolute, linear position sensors provided by MTS Sensors rely on the company's proprietary Temposonics® magnetostrictive technology, which can determine position with a high level of precision and robustness. Each Temposonics® position sensor consists of a ferromagnetic waveguide, a position magnet, a strain pulse converter and supporting electronics. The magnet, connected to the object in motion in the application, generates a magnetic field at its location on the waveguide. A short current pulse is applied to the waveguide. This creates a momentary radial magnetic field and torsional strain on the waveguide. The momentary interaction of the magnetic fields releases a torsional strain pulse that propagates the length of the waveguide. When the ultrasonic wave reaches the end of the waveguide it is converted into an electrical signal. Since the speed of the ultrasonic wave in the waveguide is precisely known, the time required to receive the return signal can be converted into a linear position measurement with both high accuracy and repeatability.

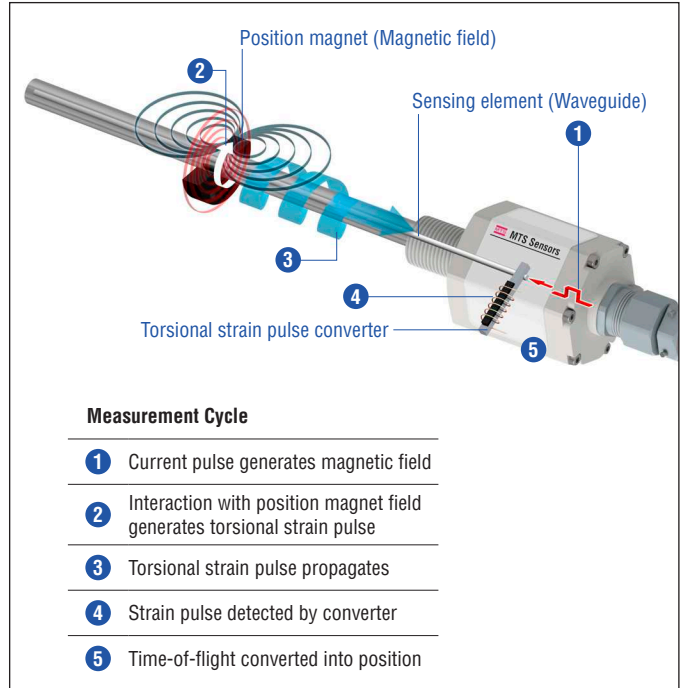

Fig. 1: Time-of-flight based magnetostrictive position sensing principle

ET SENSOR

Robust, non-contact and wear free, the Temposonics® linear position sensors provide best durability and accurate position measurement solutions in harsh industrial environments. The position measurement accuracy is tightly controlled by the quality of the waveguide which is manufactured by MTS Sensors. The position magnet is mounted on the moving machine part and travels contactlessly over the sensor rod with the built-in waveguide.

ET sensor specifications:

- High operating temperature up to +90 °C (+194 °F)
- Compact sensor housing
- ATEX / IECEx / CEC / NEC certified
- Configurable via programming kit

Certification

ⓧ II 3G Ex nC IIC T4 Gc
 ⓧ II 3D Ex tc IIIC T130 °C Dc IP66 / IP68
 Class I/II/III Div 2 T4 ABCDFG
 Class I Zone 2 T4 IIC
 Zone 22 AEx tc T4 IIIC Dc
 -40 °C ≤ Ta ≤ 90 °C, Type: 4X

Fig. 2: Certification of Temposonics® ET (version A and E)



Fig. 3: Typical application: Metal processing

TECHNICAL DATA

| Output | |
|---------------------------------------|---|
| Interface | SSI (Synchronous Serial Interface) – Differential signal in SSI standard |
| Data format | Binary, gray |
| Data length | 24 bit / 25 bit |
| Measured value | Position |
| Measurement parameters | |
| Resolution | 5 µm / 10 µm / 20 µm / 50 µm / 100 µm |
| Cycle time | Up to 3.7 kHz, depending on stroke length |
| Linearity ¹ | ≤ ±0.02 % F.S. (minimum ±60 µm) |
| Repeatability | ≤ ±0.005 % F.S. (minimum ±20 µm) typical |
| Operating conditions | |
| Operating temperature | –40...+90 °C (–40...+194 °F) |
| Humidity | 90 % relative humidity, no condensation |
| Ingress protection | Version A and E with Teflon® cable (part no. 530 112): IP66 Version A, E and N with silicone cable (part no. 530 113): IP68 (2 bar (29 psi) @ 30 min) |
| Shock test | 100 g (single shock), IEC standard 60068-2-27 |
| Vibration test | 15 g / 10...2000 Hz, IEC standard 60068-2-6 (resonance frequencies excluded) |
| EMC test | Electromagnetic emission according to EN 61000-6-4 Electromagnetic immunity according to EN 61000-6-2 The sensor meets the requirements of the EU directives and is marked with CE |
| Operating pressure | Up to 350 bar (5076 psi) |
| Magnet movement velocity ² | Any |
| Design / Material | |
| Sensor electronics housing | Stainless steel 1.4305 (AISI 303); option: Stainless steel 1.4404 (AISI 316L) |
| Flange | Stainless steel 1.4305 (AISI 303); option: Stainless steel 1.4404 (AISI 316L) |
| Sensor rod | Stainless steel 1.4306 (AISI 304L); option: Stainless steel 1.4404 (AISI 316L) |
| Stroke length | 50...3000 mm (1...118 in.) |
| Mechanical mounting | |
| Mounting position | Any |
| Mounting instruction | Please consult the technical drawings and the operation manual (document number: 551889) |
| Electrical connection | |
| Connection type | Cable outlet |
| Operating voltage | +24 VDC (–15 / +20 %) |
| Ripple | ≤ 0.28 V _{pp} |
| Current consumption | 90 mA typical, dependent on stroke length |
| Dielectric strength | 700 VDC (DC ground to machine ground) |
| Polarity protection | Up to –30 VDC |
| Overvoltage protection | Up to 36 VDC |

1/ With position magnet # 251 416-2

2/ If there is contact between the moving magnet including the magnet holder and the sensor rod, make sure that the maximal speed of the moving magnet is ≤ 1 m/s (ATEX requirement due to ESD [Electro Static Discharge])

TECHNICAL DRAWING

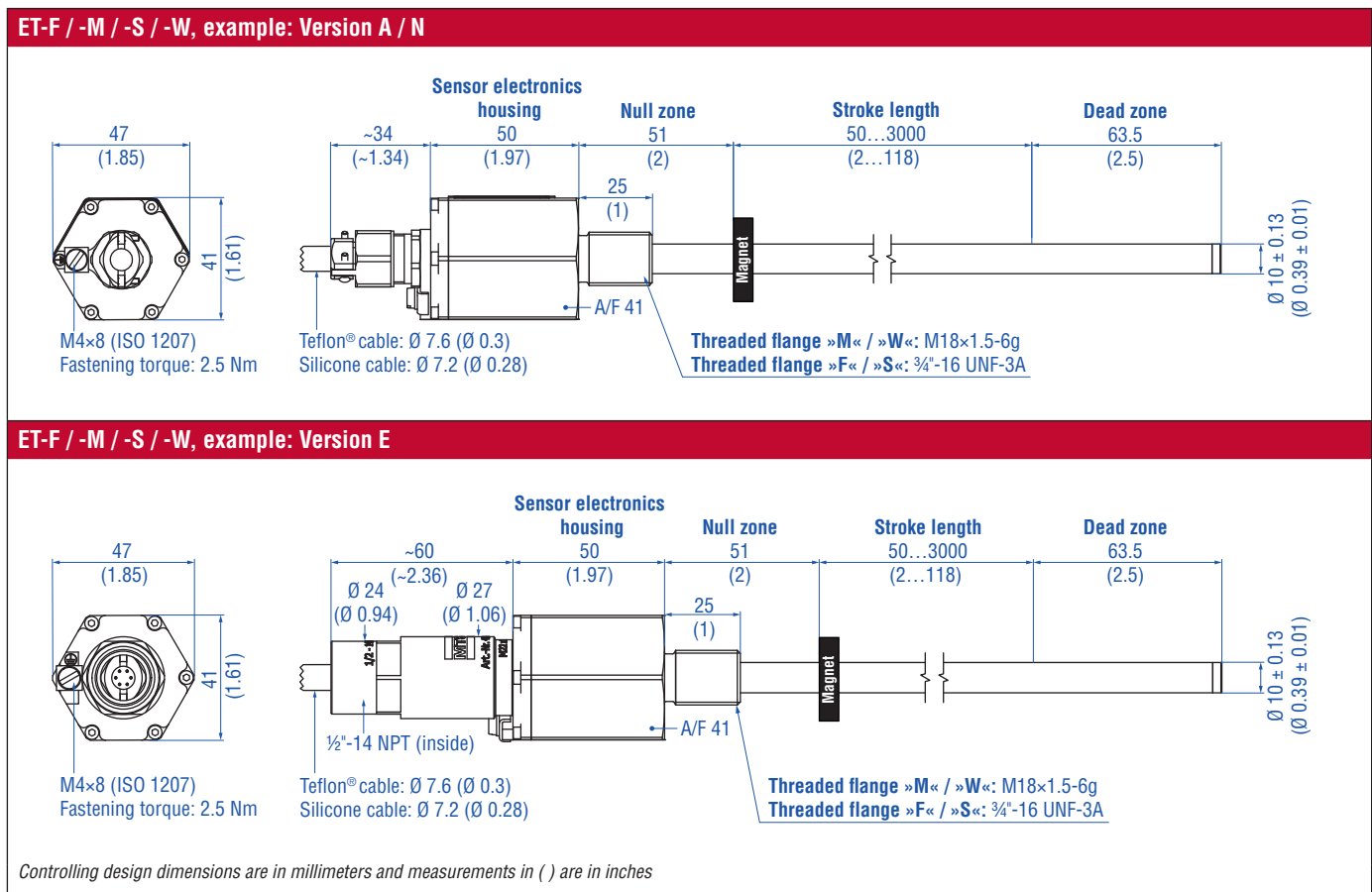



Fig. 4: Temposonics® ET with ring magnet

CONNECTOR WIRING

| TXX / VXX | | |
|-----------------------|-------|-----------------------|
| Signal + power supply | | |
| Cable | Color | Function |
| | GY | Data (-) |
| | PK | Data (+) |
| | YE | Clock (+) |
| | GN | Clock (-) |
| | BN | +24 VDC (-15 / +20 %) |
| | WH | DC Ground (0 V) |

Fig. 5: Connector wiring TXX / VXX

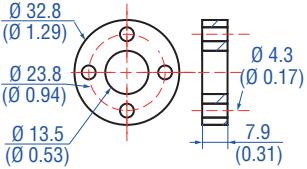
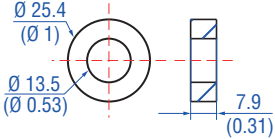
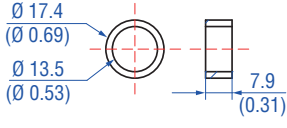
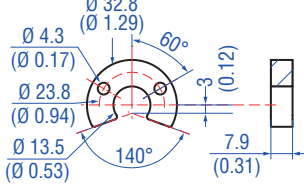
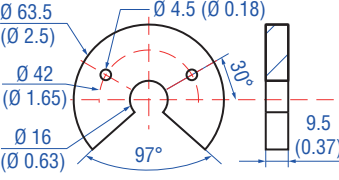
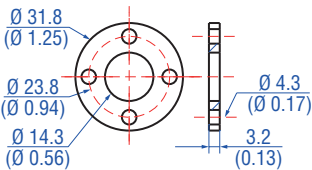
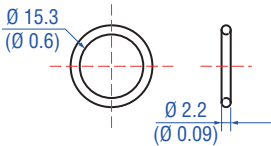
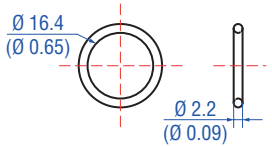

FREQUENTLY ORDERED ACCESSORIES – Additional options available in our [Accessories Guide](#)  [551444](#)

| Position magnets | | | | | |
|---|--|---|---|--------------------------------|--|
|  |  |  |  | | |
| <p>Ring magnet OD33 Part no. 201 542-2</p> <p>Material: PA ferrite GF20 Weight: Approx. 14 g Surface pressure: Max. 40 N/mm² Fastening torque for M4 screws: 1 Nm Operating temperature: -40...+105 °C (-40...+221 °F)</p> | <p>Ring magnet OD25.4 Part no. 400 533</p> <p>Material: PA ferrite Weight: Approx. 10 g Surface pressure: Max. 40 N/mm² Operating temperature: -40...+105 °C (-40...+221 °F)</p> | <p>Ring magnet OD17.4 Part no. 401 032</p> <p>Material: PA neobind Weight: Approx. 5 g Surface pressure: Max. 20 N/mm² Operating temperature: -40...+105 °C (-40...+221 °F)</p> | <p>U-magnet OD33 Part no. 251 416-2</p> <p>Material: PA ferrite GF20 Weight: Approx. 11 g Surface pressure: Max. 40 N/mm² Fastening torque for M4 screws: 1 Nm Operating temperature: -40...+105 °C (-40...+221 °F)</p> | | |
| Position magnet | | Magnet spacer | | Optional installation hardware | |
|  |  |  |  | | |
| <p>U-magnet OD63.5 Part no. 201 553</p> <p>Material: PA 66-GF30, magnets compound-filled Weight: Approx. 26 g Surface pressure: 20 N/mm² Fastening torque for M4 screws: 1 Nm Operating temperature: -40...+75 °C (-40...+167 °F)</p> | <p>Magnet spacer Part no. 400 633</p> <p>Material: Aluminum Weight: Approx. 5 g Surface pressure: Max. 20 N/mm² Fastening torque for M4 screws: 1 Nm</p> | <p>O-ring for threaded flange M18x1.5-6g Part no. 401 133</p> <p>Material: Fluoroelastomer 75 ± 5 durometer Operating temperature: -40...+204 °C (-40...+400 °F)</p> | <p>O-ring for threaded flange 3/4"-16 UNF-3A Part no. 560 315</p> <p>Material: Fluoroelastomer 75 ± 5 durometer Operating temperature: -40...+204 °C (-40...+400 °F)</p> | | |

Manuals, Software & 3D Models available at:
www.mtssensors.com

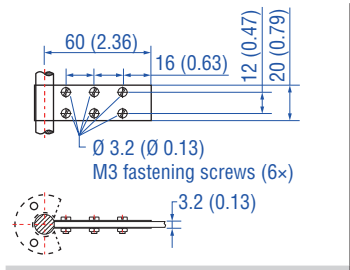
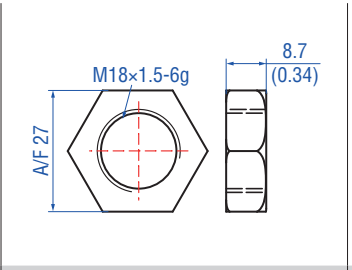
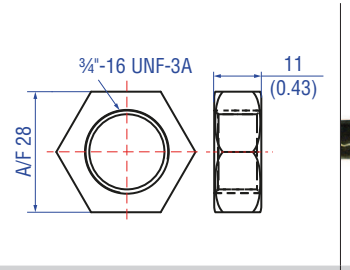
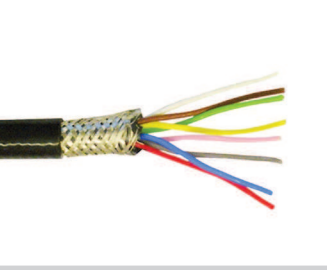
Controlling design dimensions are in millimeters and measurements in () are in inches

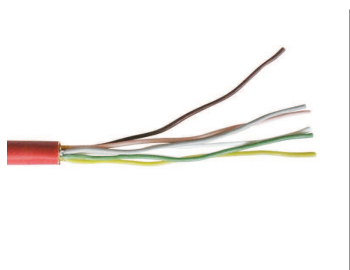
| Optional installation hardware | | Cable | |
|--|---|--|--|
|  |  |  |  |
| <p>Fixing clip for rod with Ø 10 mm Part no. 561 481</p> | <p>Hex jam nut M18x1.5-6g Part no. 500 018</p> | <p>Hex jam nut ¾"-16 UNF-3A Part no. 500 015</p> | <p>Teflon® cable Part no. 530 112</p> |
| <p>Application: Used to secure sensor rods (Ø 10 mm (Ø 0.39 in.)) when using an U-magnet Material: Brass, non-magnetic</p> | <p>Material: Steel, zinc, plated</p> | <p>Material: Zinc plated with nylon insert</p> | <p>Name of cable in order code: T Material: Teflon® jacket; black Features: Twisted pair shielded Cable Ø: 7.6 mm (0.3 in.) Dimensions: 4 × 2 × 0.25 mm² Bending radius: 8 – 10 × Ø (fixed installation) Operating temperature: –100...+180 °C (–148...+356 °F)</p> |

| Cable | Programming tool ³ |
|--|--|
|  |  |
| <p>Silicone cable Part no. 530 113</p> <p>Name of cable in order code: V</p> <p>Material: Silicone jacket; red Features: Twisted pair, shielded Cable Ø: 7.2 mm (0.3 in.) Dimensions: 3 × 2 × 0.25 mm² Bending radius: 5 × Ø (fixed installation) Operating temperature: –50...+180 °C (–58...+356 °F)</p> | <p>Programming kit Part no. 254 590</p> <p>Kit includes: Interface converter box, power supply, cable software is available at: www.mtssensors.com</p> |

Manuals, Software & 3D Models available at:
www.mtssensors.com

Controlling design dimensions are in millimeters and measurements in () are in inches
3/ The programming tool is not approved for use in hazardous environments

ORDER CODE

| | | | | | | | | | | | | | | | | | | | | |
|---|---|---|---|---|---|---|---|---|----|----|----|----|----|----|----|----|----|----|----|--|
| 1 | 2 | 3 | 4 | 5 | 6 | 7 | 8 | 9 | 10 | 11 | 12 | 13 | 14 | 15 | 16 | 17 | 18 | 19 | 20 | |
| E | T | | | | | | | | | | 1 | | S | | | | | | | |
| a | | b | c | | | | | d | | | e | f | g | | | | | | | |

| | |
|----------|---------------------|
| a | Sensor model |
| E T | Rod |

| | |
|--|------------------------------|
| b | Design |
| ET rod-style sensor with housing and sensor rod material stainless steel 1.4404 (AISI 316L) | |
| F | Threaded flange ¾"-16 UNF-3A |
| W | Threaded flange M18×1.5-6g |
| ET rod-style sensor with housing material stainless steel 1.4305 (AISI 303) and sensor rod material stainless steel 1.4306 (AISI 304L) | |
| M | Threaded flange M18×1.5-6g |
| S | Threaded flange ¾"-16 UNF-3A |

| | |
|--------------------------------------|----------------------|
| c | Stroke length |
| X X X X M | 0050...3000 mm |
| Standard stroke length (mm)* | |
| | Ordering steps |
| 50 ... 500 mm | 5 mm |
| 500 ... 750 mm | 10 mm |
| 750...1000 mm | 25 mm |
| 1000...2500 mm | 50 mm |
| 2500...3000 mm | 100 mm |
| X X X X U | 002.0...118.0 in. |
| Standard stroke length (in.)* | |
| | Ordering steps |
| 2 ... 20 in. | 0.2 in. |
| 20 ... 30 in. | 0.5 in. |
| 30 ... 40 in. | 1.0 in. |
| 40...100 in. | 2.0 in. |
| 100...116 in. | 4.0 in. |

| | |
|----------|--|
| d | Connection type |
| T X X | T01...T10 (1...10 m) 4 XX m Teflon® cable (part no. 530 112) T03...T33 (3...33 ft) 4 XX ft Teflon® cable (part no. 530 112) |
| V X X | V01...V10 (1...10 m) 4 XX m silicone cable (part no. 530 113) V03...V33 (3...33 ft) 4 XX ft silicone cable (part no. 530 113) |

| | |
|----------|--------------------------|
| e | Operating voltage |
| 1 | +24 VDC (-15 / +20 %) |

| | |
|----------|---|
| f | Version (see "Certification of Temposonics® ET (version A and E)" on page 2 for further information) |
| A | ATEX / IECEx / CEC / NEC |
| E | ATEX / IECEx / CEC / NEC with ½" NPT adapter |
| N | Not approved |

NOTICE
Version E (section **f**) is only available with design »M« and »S« (section **b**).

| | |
|---|--|
| g | Output |
| S (15) (16) (17) (18) (19) (20) = Synchronous Serial Interface | |
| Data length (box no. 15) | |
| 1 | 25 bit |
| 2 | 24 bit |
| Output format (box no. 16) | |
| B | Binary |
| G | Gray |
| Resolution (box no. 17) | |
| 1 | 0.005 mm |
| 2 | 0.01 mm |
| 3 | 0.05 mm |
| 4 | 0.1 mm |
| 5 | 0.02 mm |
| Filtering performance (box no. 18) | |
| 1 | No filter |
| 2 | Average filter 2 |
| 3 | Average filter 4 |
| 4 | Average filter 8 |
| Signal options (box no. 19, 20) | |
| 0 0 | Measuring direction forward, asynchronous mode |
| 0 1 | Measuring direction reverse, asynchronous mode |
| 0 2 | Measuring direction forward, synchronous mode |
| 0 3 | Measuring direction reverse, synchronous mode |

* / Non standard stroke lengths are available; must be encoded in 5 mm / 0.1 in. increments

4/ Encode in meters if using metric stroke length. Encode in feet if using US customary stroke length

DELIVERY



Sensor

Accessories have to be ordered separately

Manuals, Software & 3D Models available at:
www.mtssensors.com

Document Part Number:
551899 Revision B (EN) 10/2017

LOCATIONS

USA
MTS Systems Corporation
Sensors Division
3001 Sheldon Drive
Cary, N.C. 27513, USA
Tel. +1 919 677-0100
Fax +1 919 677-0200
info.us@mtssensors.com
www.mtssensors.com

JAPAN
MTS Sensors Technology Corp.
737 Aihara-machi,
Machida-shi,
Tokyo 194-0211, Japan
Tel. +81 42 775-3838
Fax +81 42 775-5512
info.jp@mtssensors.com
www.mtssensors.com

FRANCE
MTS Systems SAS
Zone EUROPARC Bâtiment EXA 16
16/18, rue Eugène Dupuis
94046 Creteil, France
Tel. +33 1 58 4390-28
Fax +33 1 58 4390-03
info.fr@mtssensors.com
www.mtssensors.com

GERMANY
MTS Sensor Technologie
GmbH & Co. KG
Auf dem Schüffel 9
58513 Lüdenscheid, Germany
Tel. +49 2351 9587-0
Fax +49 2351 56491
info.de@mtssensors.com
www.mtssensors.com

CHINA
MTS Sensors
Room 504, Huajing Commercial Center,
No. 188, North Qinzhou Road
200233 Shanghai, China
Tel. +86 21 6485 5800
Fax +86 21 6495 6329
info.cn@mtssensors.com
www.mtssensors.com

ITALY
MTS Systems Srl
Sensor Division
Via Camillo Golgi, 5/7
25064 Gussago (BS), Italy
Tel. +39 030 988 3819
Fax +39 030 982 3359
info.it@mtssensors.com
www.mtssensors.com

LEGAL NOTICES

MTS, Temposonics and Level Plus are registered trademarks of MTS Systems Corporation in the United States; MTS SENSORS and the MTS SENSORS logo are trademarks of MTS Systems Corporation within the United States. These trademarks may be protected in other countries. All other trademarks are the property of their respective owners. Copyright © 2017 MTS Systems Corporation. No license of any intellectual property rights is granted. MTS reserves the right to change the information within this document, change product designs, or withdraw products from availability for purchase without notice. Typographic and graphics errors or omissions are unintentional and subject to correction. Visit www.mtssensors.com for the latest product information.

